

Make from 0.4" x 0.4" x 0.4" brass or aluminum.
 Locate drilled hole by using pointed screw in tapped hole in Lathe Saddle

Notes: Drill and tap Lathe Saddle for 10-32 screw located 0.20" from left edge and 0.20" from bottom edge.

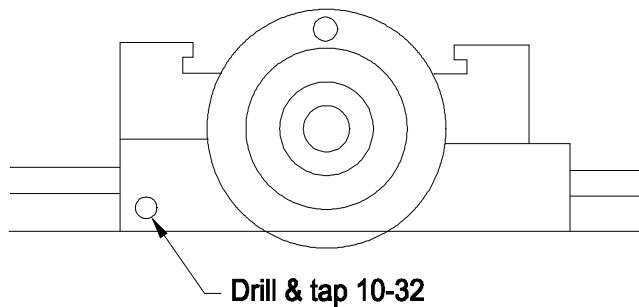

borisbrooks.com

**SHERLINE LATHE
 SADDLE LOCK**

1" = 0.2"

Drawn by: J. E. Rickenbacker

Date: 31 Oct 2004

Page 1 of 1